

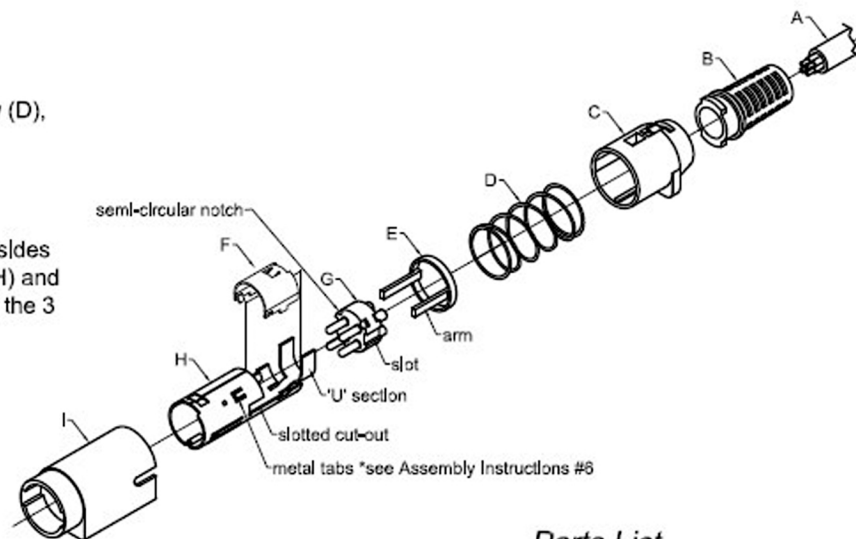

## Assembly Instructions

- 1) Attach *Strain Relief (B)* to *Plastic Enclosure (C)*.
- 2) Pass *Cable (A)* through *Strain Relief (B)/Plastic Enclosure (C)* assembly, *Metal Spring (D)*, and *Plastic Guide Ring (E)*.
- 3) Solder cable wires to solder cups on *Pin Mold (G)*.
- 4) Properly align *Pin Mold (G)* with *Lower Metal Sleeve (H)*. The slotted sections on the sides of the *Pin Mold (G)* must line up with the slotted cut-outs on the *Lower Metal Sleeve (H)* and the 3 semi-circular notches around the perimeter of the *Pin Mold (G)* must line up with the 3 metal tabs inside the *Lower Metal Sleeve (H)*.
- 5) Push *Pin Mold (G)* forward into the *Lower Metal Sleeve (H)* until it locks into place.
- 6) **\*IMPORTANT\*** Manually press the 3 metal tabs on the *Lower Metal Sleeve (H)* all the way into the notches in the *Pin Mold (G)* until they rest on the plastic.
- 7) Crimp "U" section of *Lower Metal Sleeve (H)* onto *Cable (A)*.
- 8) Fit *Plastic Ring Guide (E)* into *Lower Metal Sleeve (H)* by placing plastic arms into the appropriate slots on the sides of the sleeve.
- 9) Attach *Top Metal Cover (F)* onto *Lower Metal Sleeve (H)*. Be sure to align all tabs and securely install cover.
- 10) Push *Metal Spring (D)* onto the *Top Metal Cover (F)/Lower Metal Sleeve (H)* assembly. This will help to hold the assembly together.
- 11) Push *Strain Relief (B)/Plastic Enclosure (C)* assembly onto the *Top Metal Cover (F)/Lower Metal Sleeve (H)* assembly. The two assemblies must be properly aligned as shown in the drawing. Be sure to check that the *Metal Spring (D)* remains in place and does not go underneath either the *Plastic Enclosure (C)* or the *Plastic Guide (E)* or twists during assembly. A significant amount of force may be necessary to lock the two assemblies together.
- 12) Press metal tab located on *Top metal Cover (F)* into gap in *Plastic Enclosure (C)*
- 13) Check to make sure that the *Strain Relief (B)/Plastic Enclosure (C)* assembly is securely locked into place over the *Top Metal Cover (F)/Lower Metal Sleeve (H)* assembly. The two assemblies should not be able to be pulled apart.
- 14) Properly align the new assembly with the *Plastic Coupling (I)* as shown in the drawing. Push assembly (twisting plastic enclosure "C" part) into *Plastic Coupling (I)* until it locks properly into place. The entire plug assembly is now complete.



## Parts List

- A - Customer Cable
- B - Strain Relief
- C - Plastic Enclosure
- D - Metal Spring
- E - Plastic Guide
- F - Top Metal Cover
- G - Pin Mold
- H - Lower Metal Sleeve
- I - Plastic Coupling

Part-Nr.:	42037 - Mini-DIN Steckverbinder MDIN04PP		
	42059 - Mini-DIN Steckverbinder MDIN03PP		
Erstellt:	21.07.2020		